



Patrick Tufts | Gannon McHugh | Kara Young | Jack Thrun
Summer 2018

01 BRAND ANALYSIS



ANALYSIS | BRAND TRIANGLE

PERSONALITY

Enriching society through technology and ideas.

Trustworthiness / Creativity

VALUES

Ambitious

Curious

Confident

In Control

Prideful

EMOTIONAL REWARDS

Unlimited Potential

Empowered

Professional

Satisfied

Sophisticated

FUNCTIONAL BENEFITS

Enhanced Imaging

Precise Measurement

Specific Control

Scientific Roots

ATTRIBUTES

Nikon is one of the world's leading suppliers of products and solutions based on advanced opto-electronics and precision technologies for both consumer and commercial use in the fields of bioscience, digital information, sporting, and photography.



PRECISION EQUIPMENT
LITHOGRAPHY



HEALTHCARE
MICROSCOPES



INDUSTRIAL METROLOGY
MEASURING SYSTEMS



IMAGING PRODUCTS
CAMERAS





COMPACT



ACTION



ADVANCED



DSLR



FILM



COMPACT

ENTRY LEVEL KIT FOR
ASPIRING FILM MAKERS



DSLR

- 1** Nikon NSK01 is for someone who is more serious than a point and shoot user but not yet skilled enough for the full functionality of a DSLR.
- 2** Nikon is not currently the brand of choice for film makers. Nikon NSK01 will act as the building blocks upon which Nikon can build a new lineup geared towards film makers.
- 3** Similar to Nikon's action camera lineup, NSK doesn't try to fit within the DSLR family, but rather it stands on its own as a product lineup within the camera business segment.

02 DESIGN PHASE

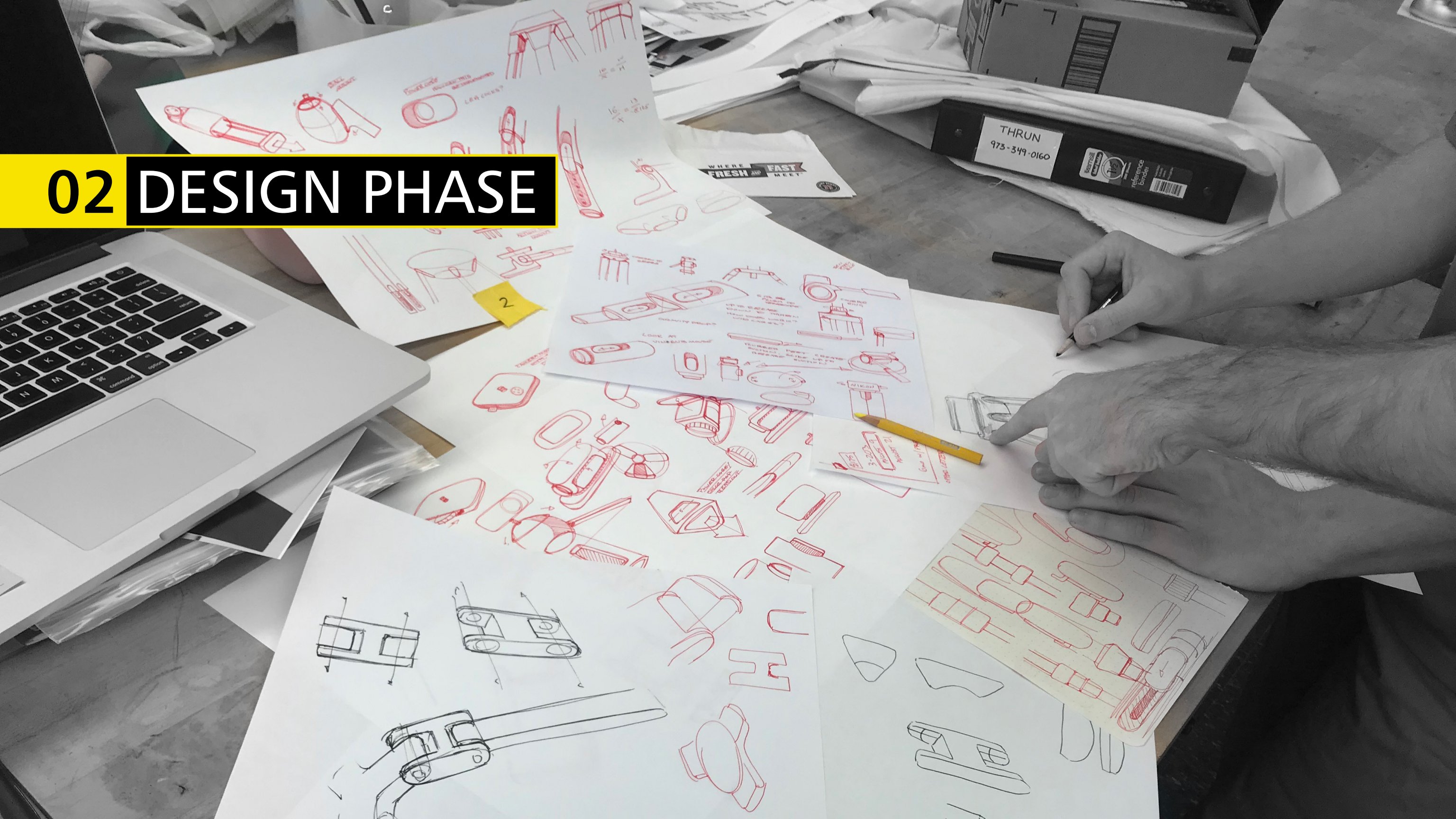

DESIGN | PERSONA

Target Market

_Amateur film maker

Profile

_Age 15 - 25

_Loves film camp

_Creative

_Able to generate ideas for

- stories

- music

- film production elements

_Style conscious

Values

_Owning their own gear

_Ease of use

_Low cost

_Adaptability



POWER CORE



PURE GEOMETRY



TOUCH POINT COLOR POPS

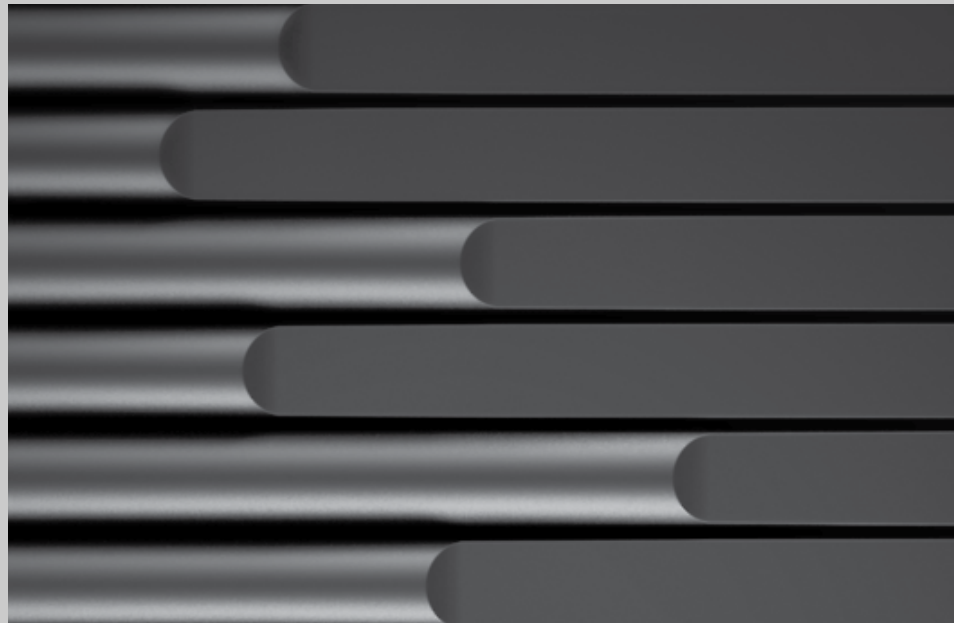

SLICED



ANODIZED DETAILS



TEXTURED

ROUGH SKETCH | CAMERA

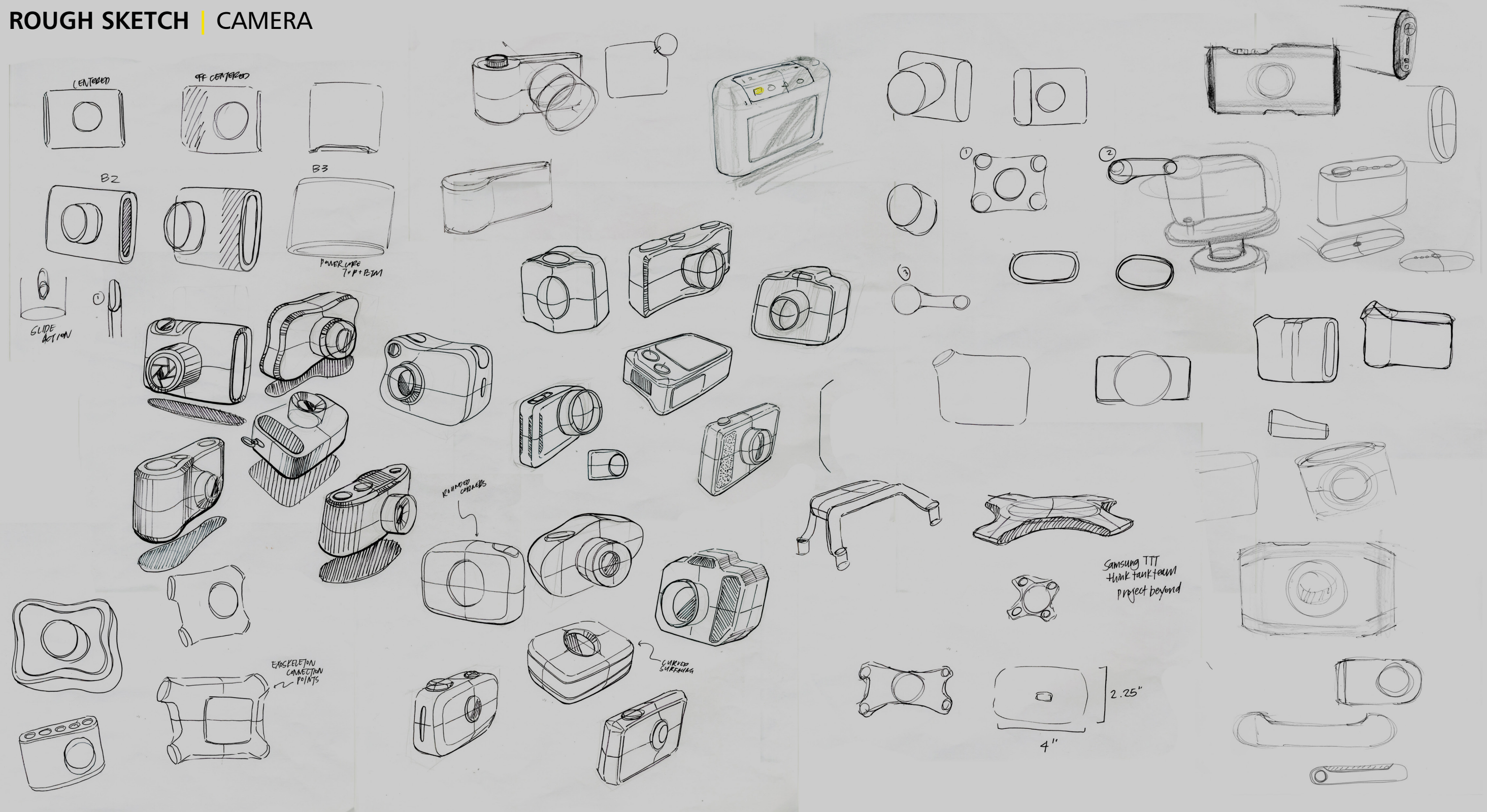

ROUGH SKETCH | MICROPHONE

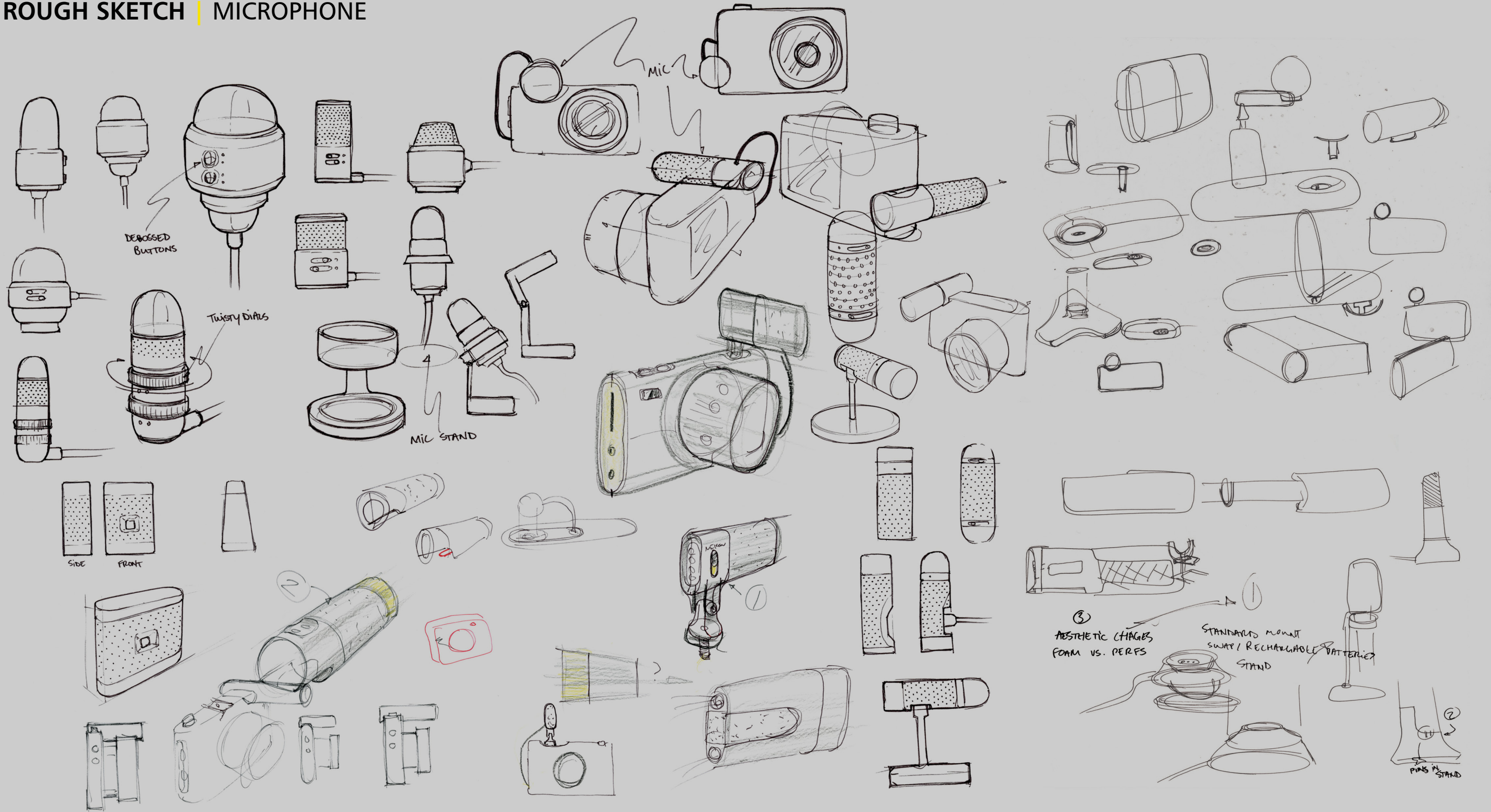

ROUGH SKETCH | TRIPOD

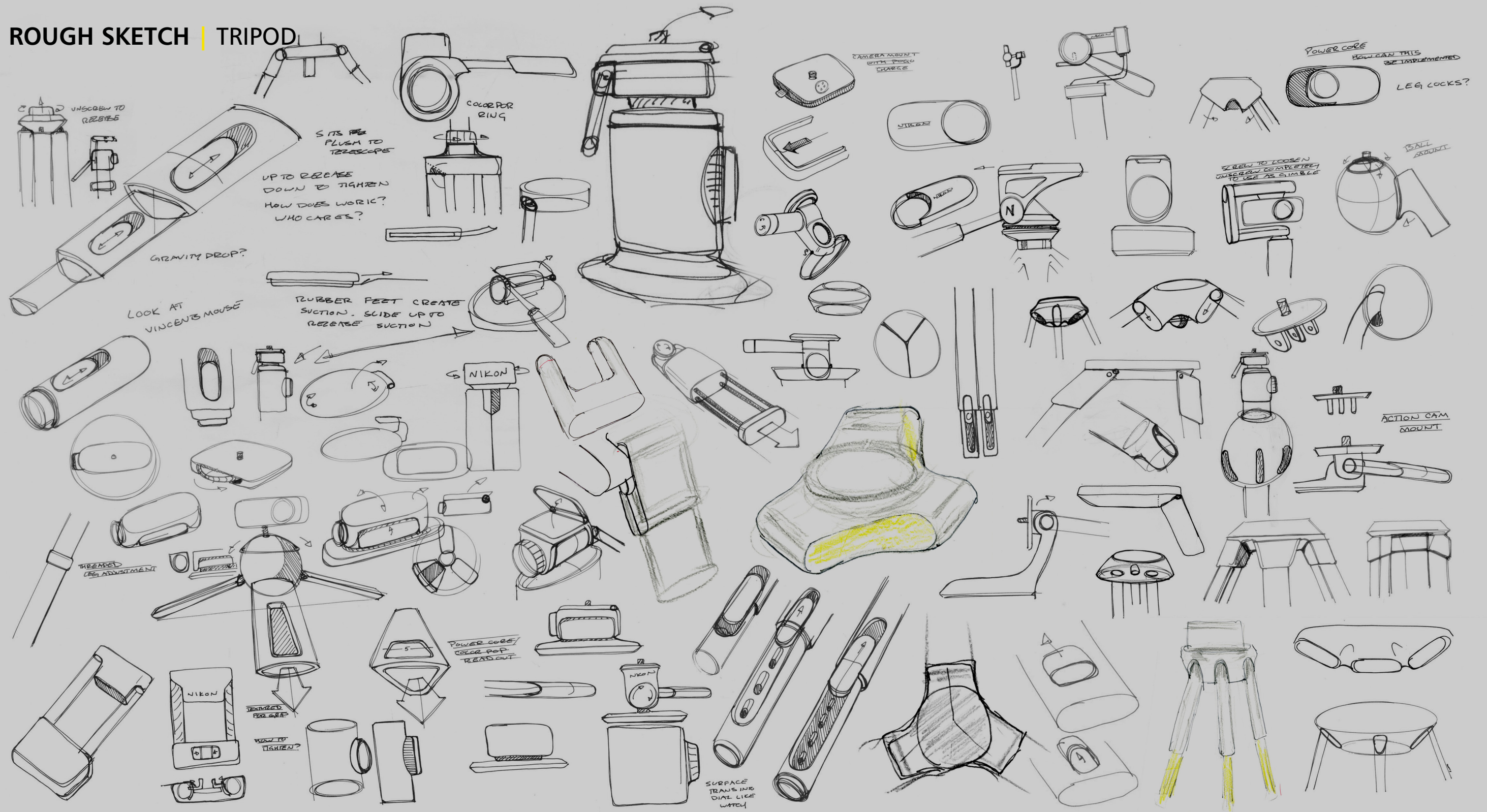

ROUGH SKETCH | DRONE

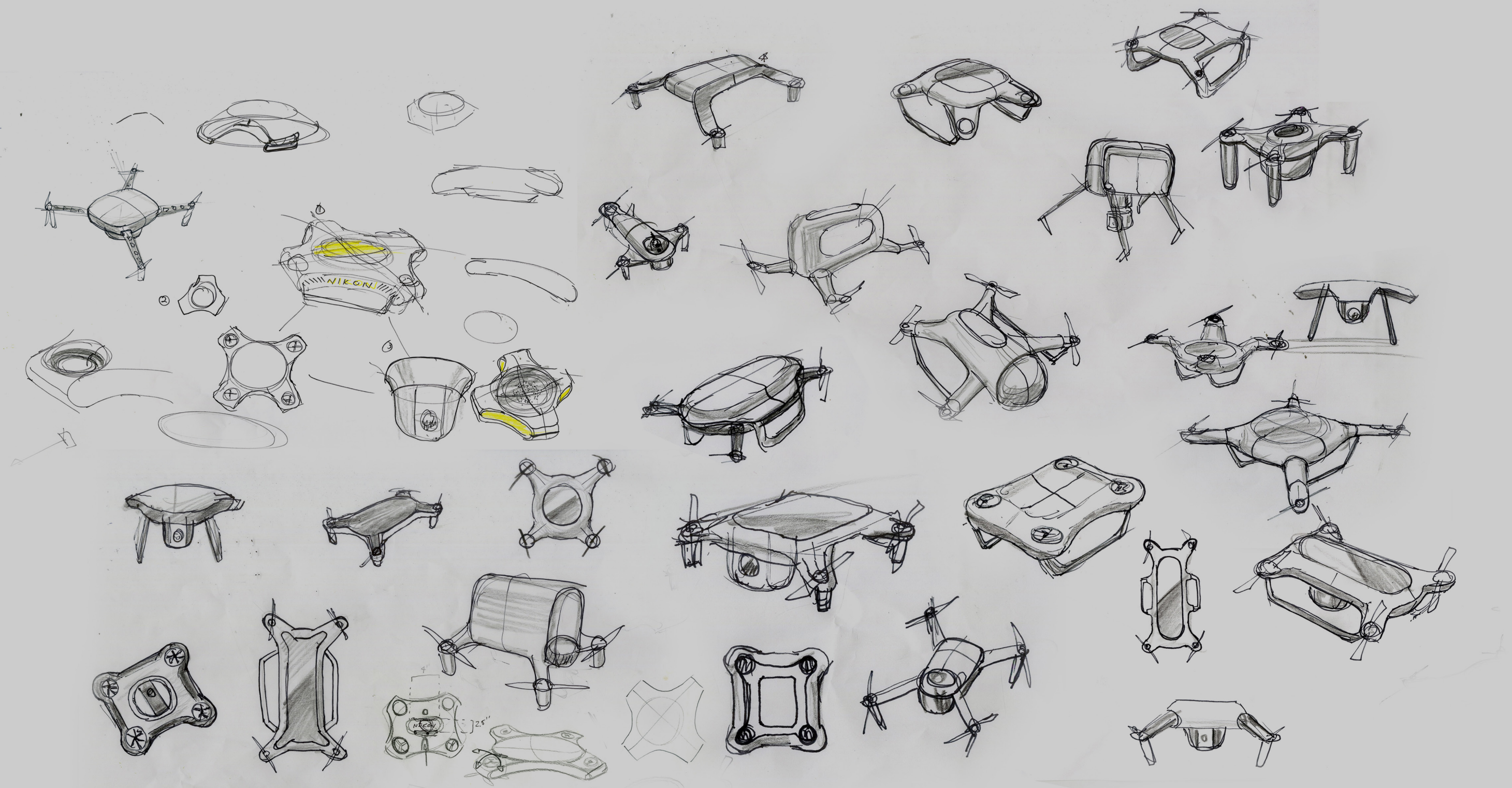

REFINED SKETCH | CAMERA



REFINED SKETCH | MICROPHONE

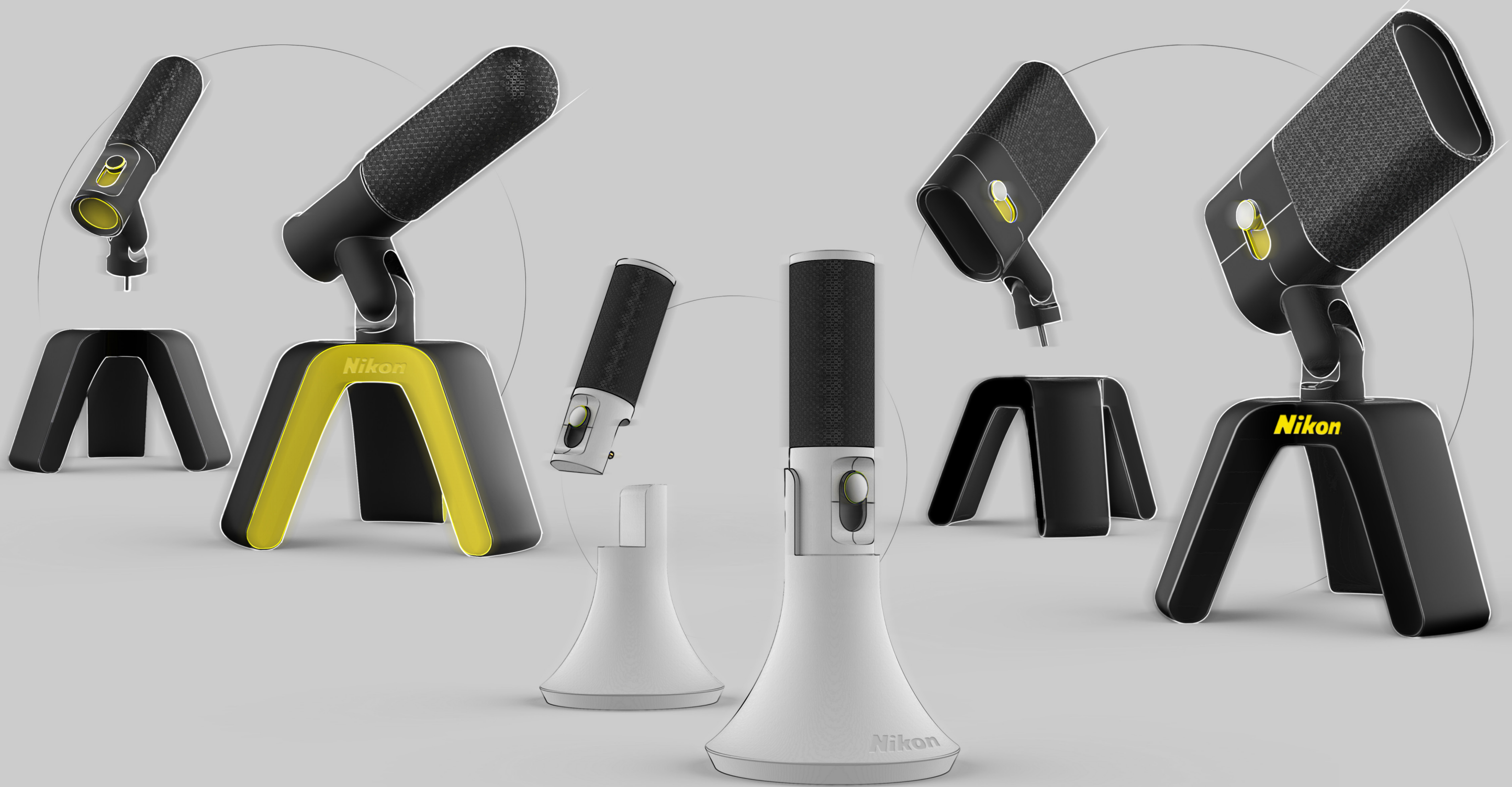

REFINED SKETCH | TRIPOD

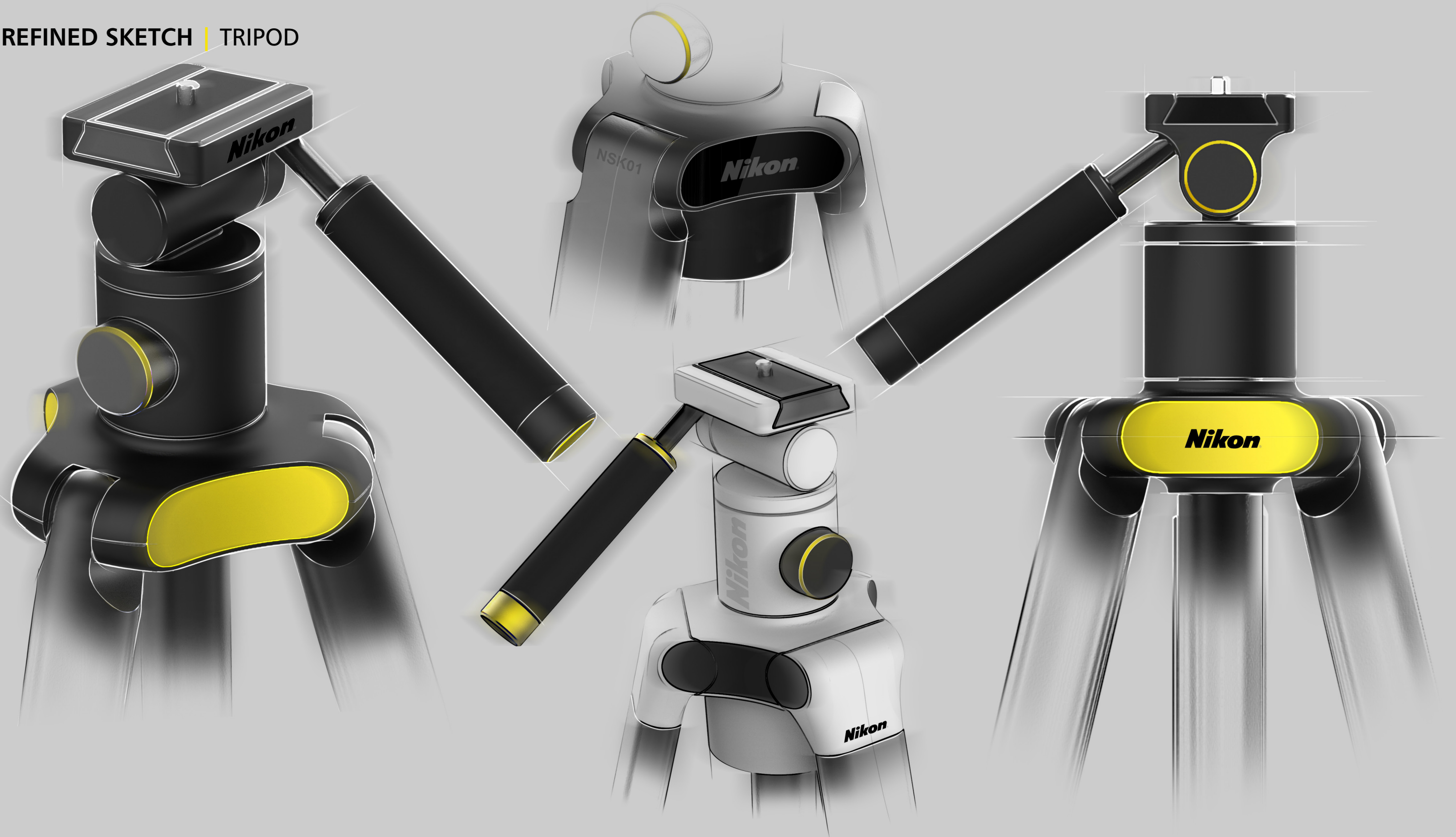

REFINED SKETCH | DRONE





MIDNIGHT BLACK

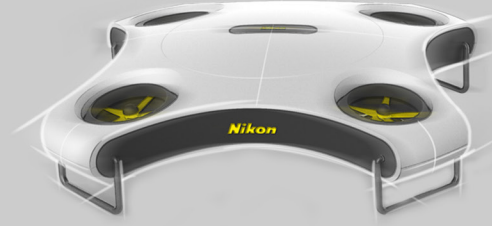
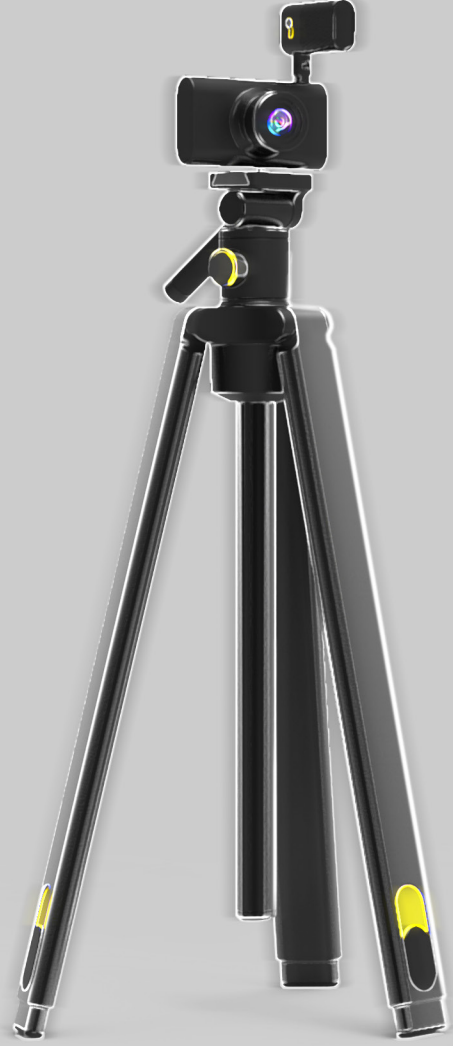

STORM TROOPER

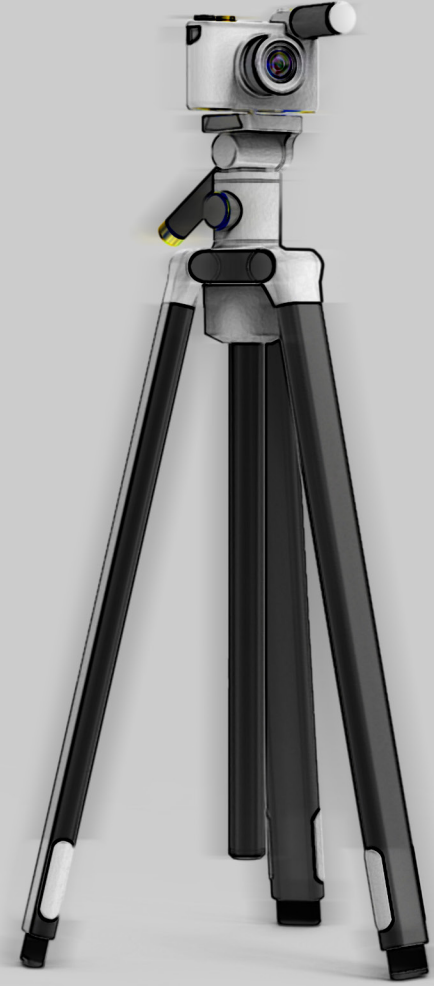

YELLOW JACKET

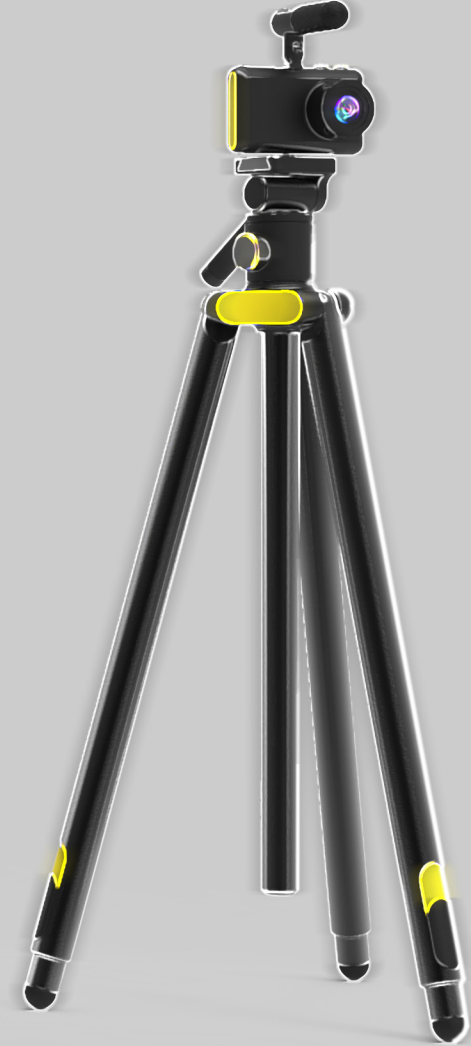



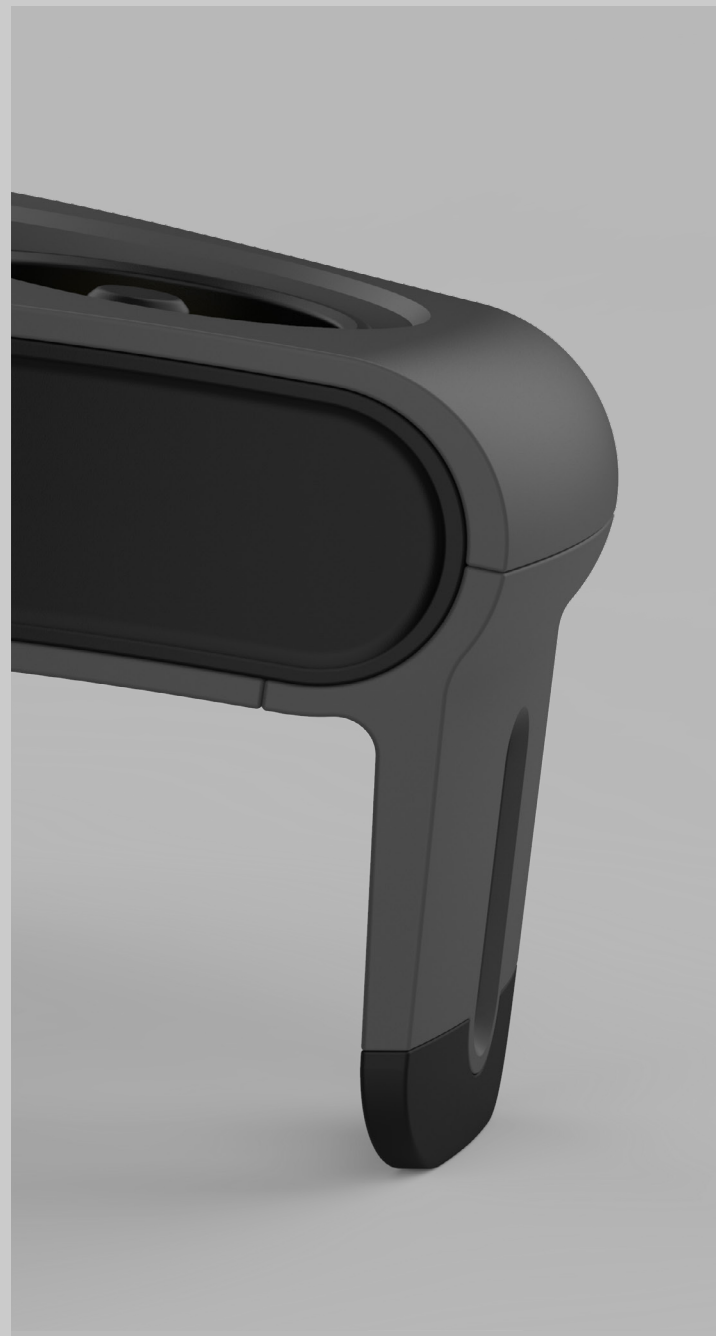

POWER CORE



SLICED



PURE GEOMETRY



AND COLOR POPS

NSK01 | CAMERA



NSK01 | CAMERA

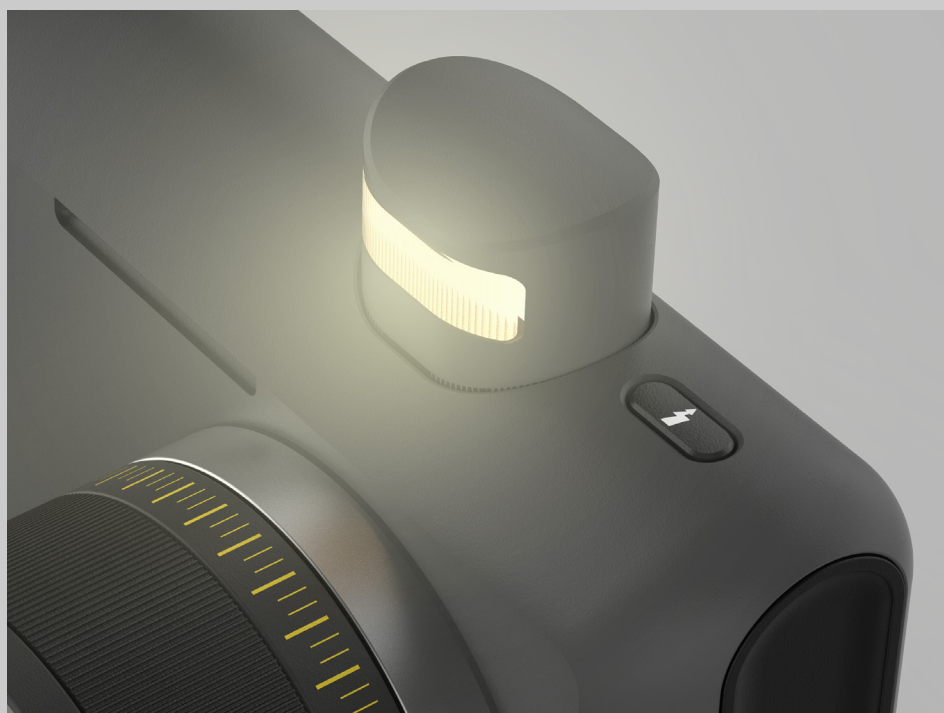
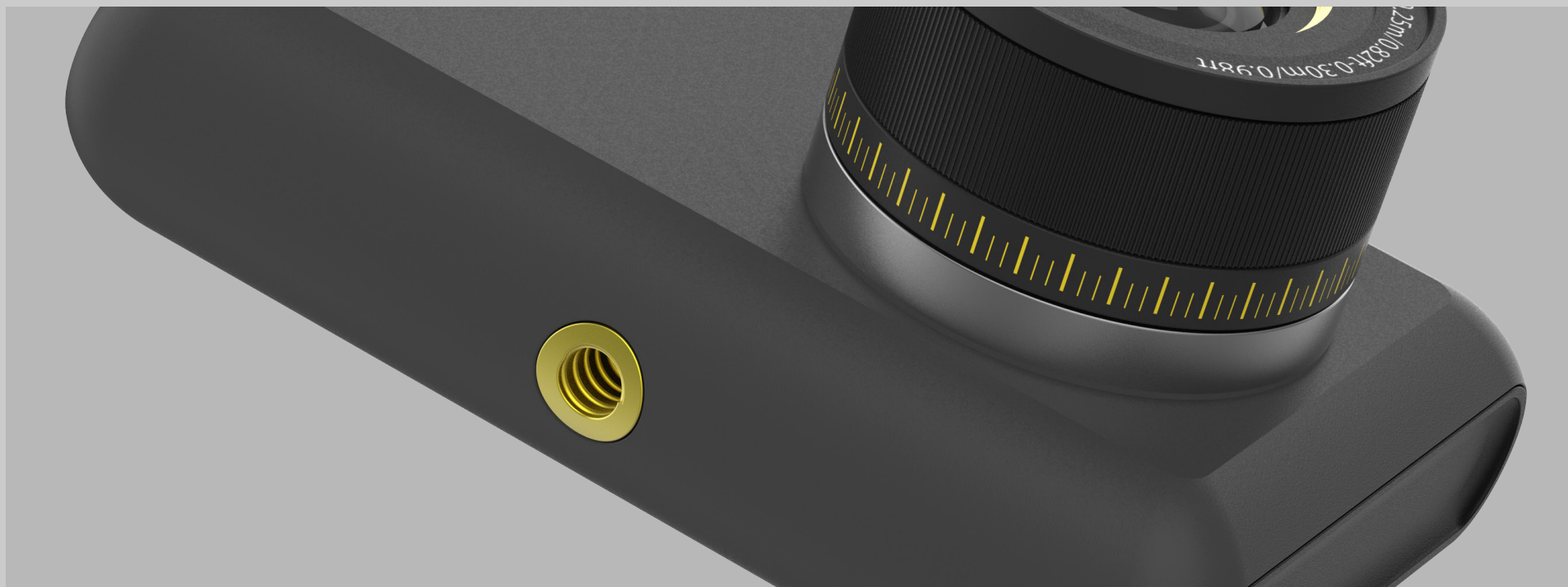

NSK01 | MICROPHONE



NSK01 | MICROPHONE

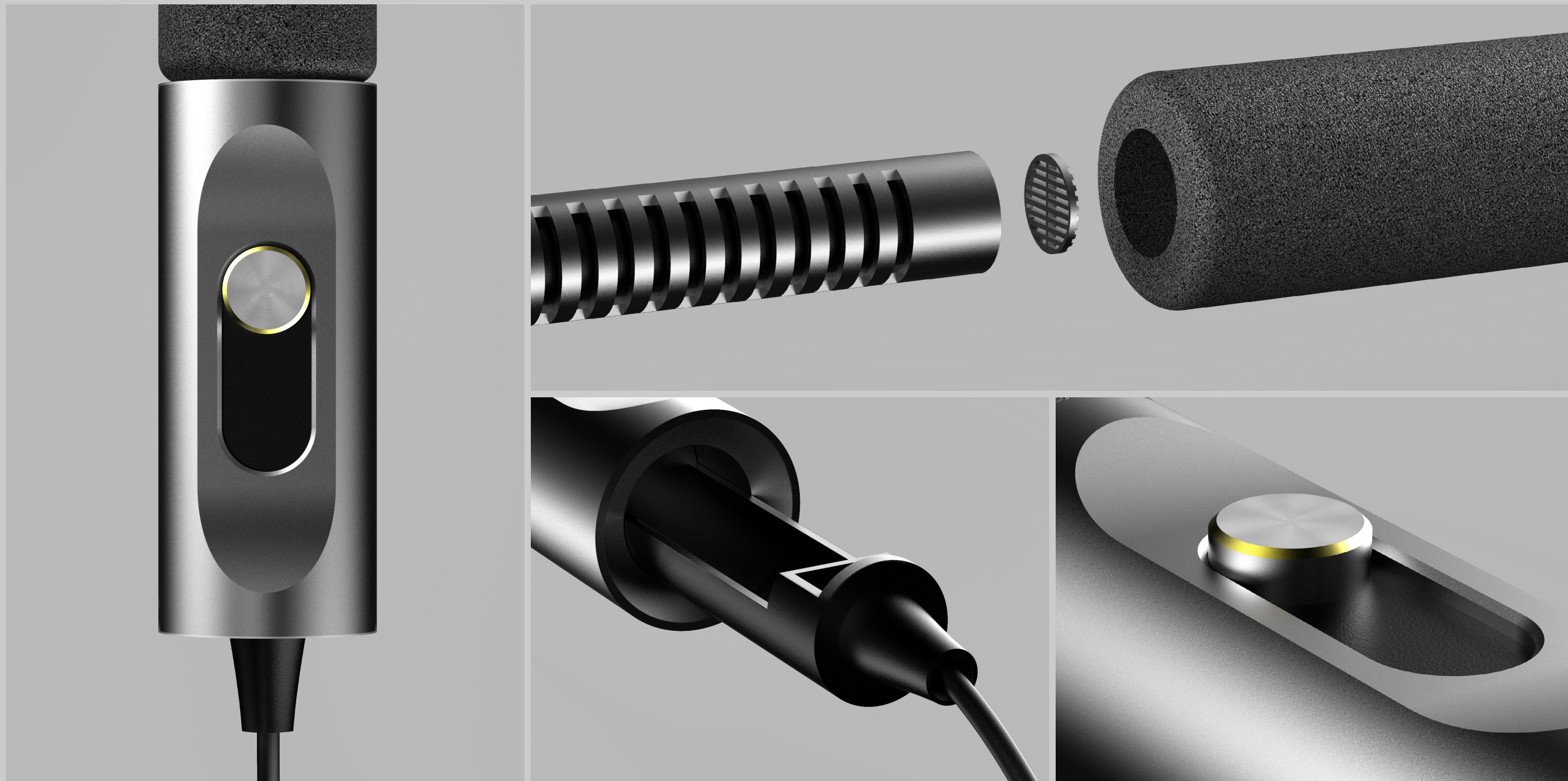

NSK01 | TRIPOD

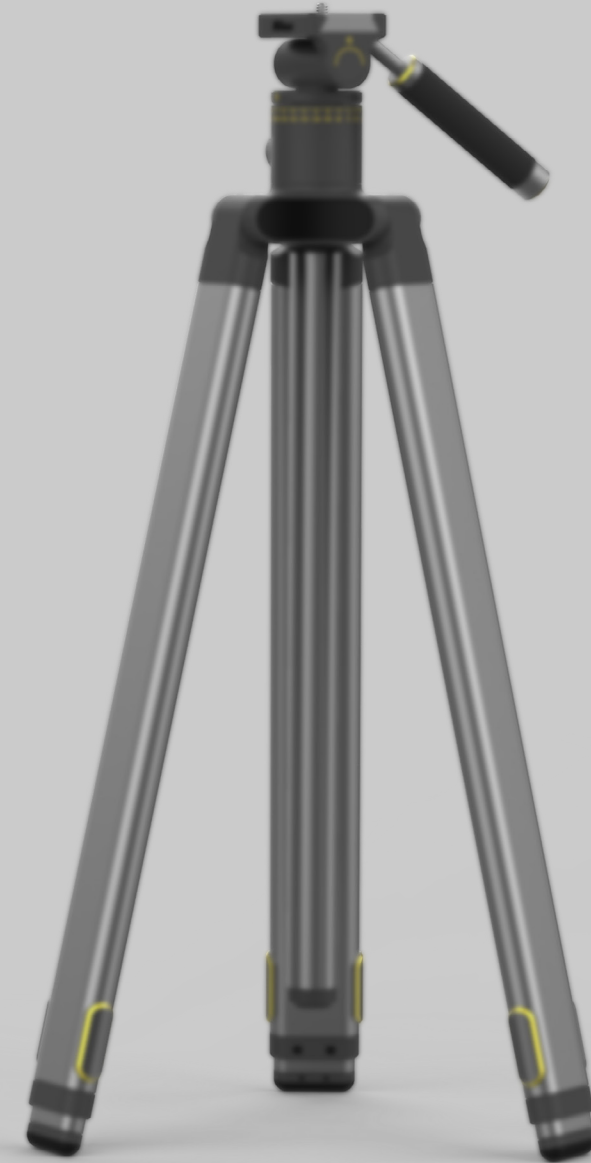

NSK01 | TRIPOD

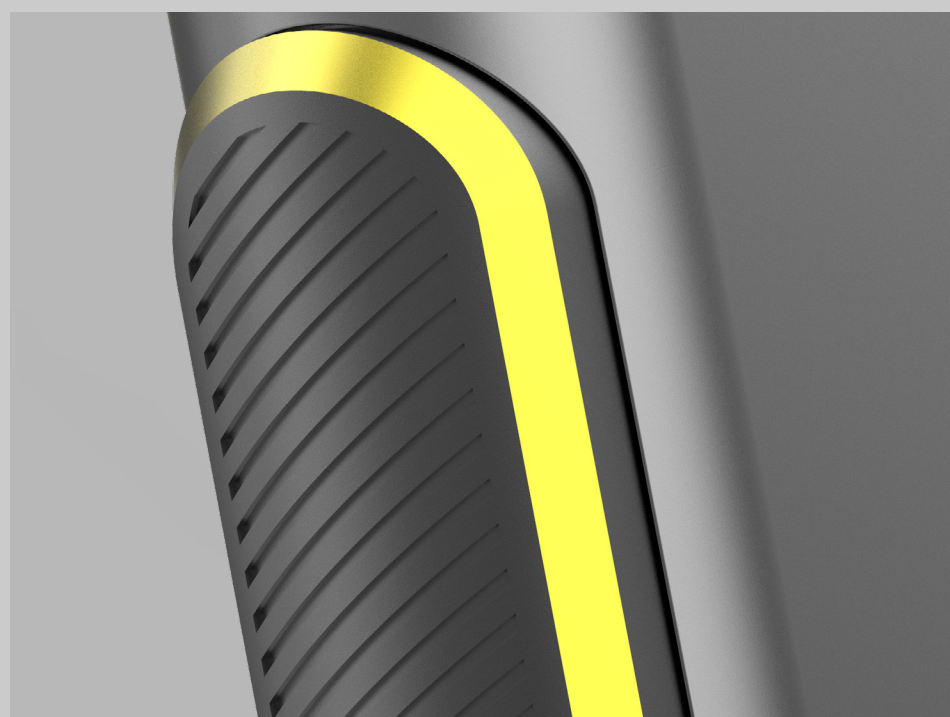
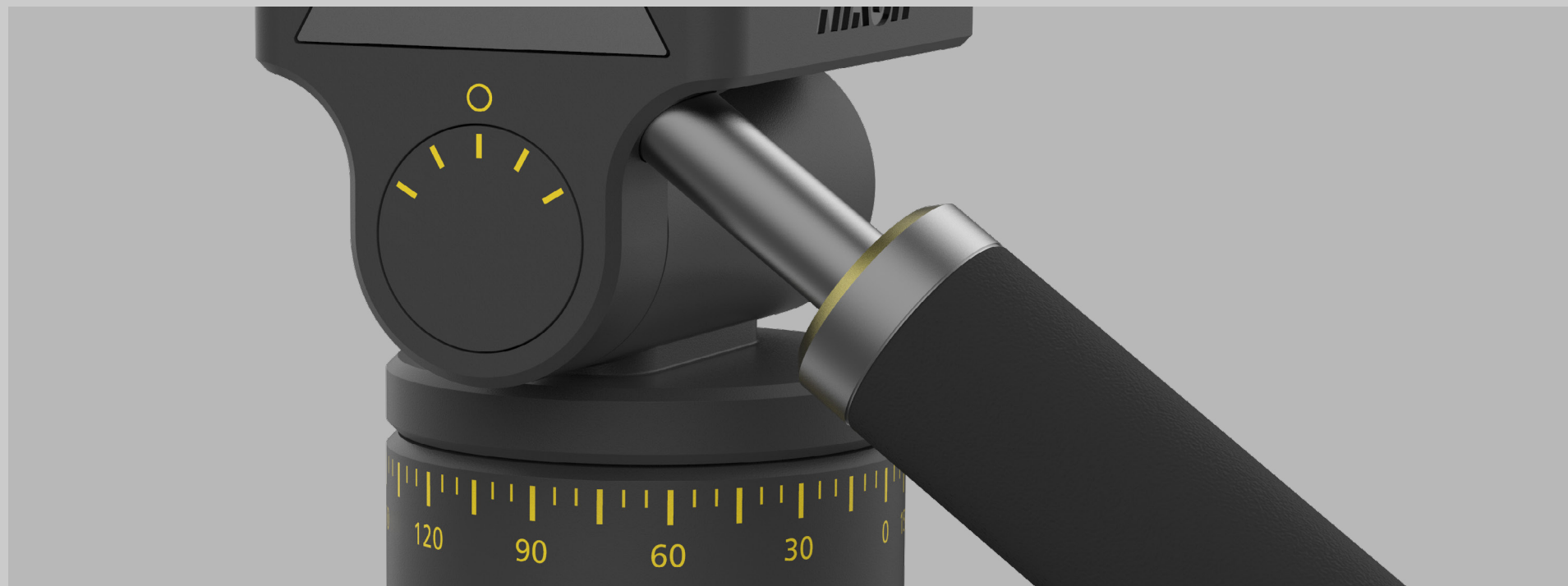
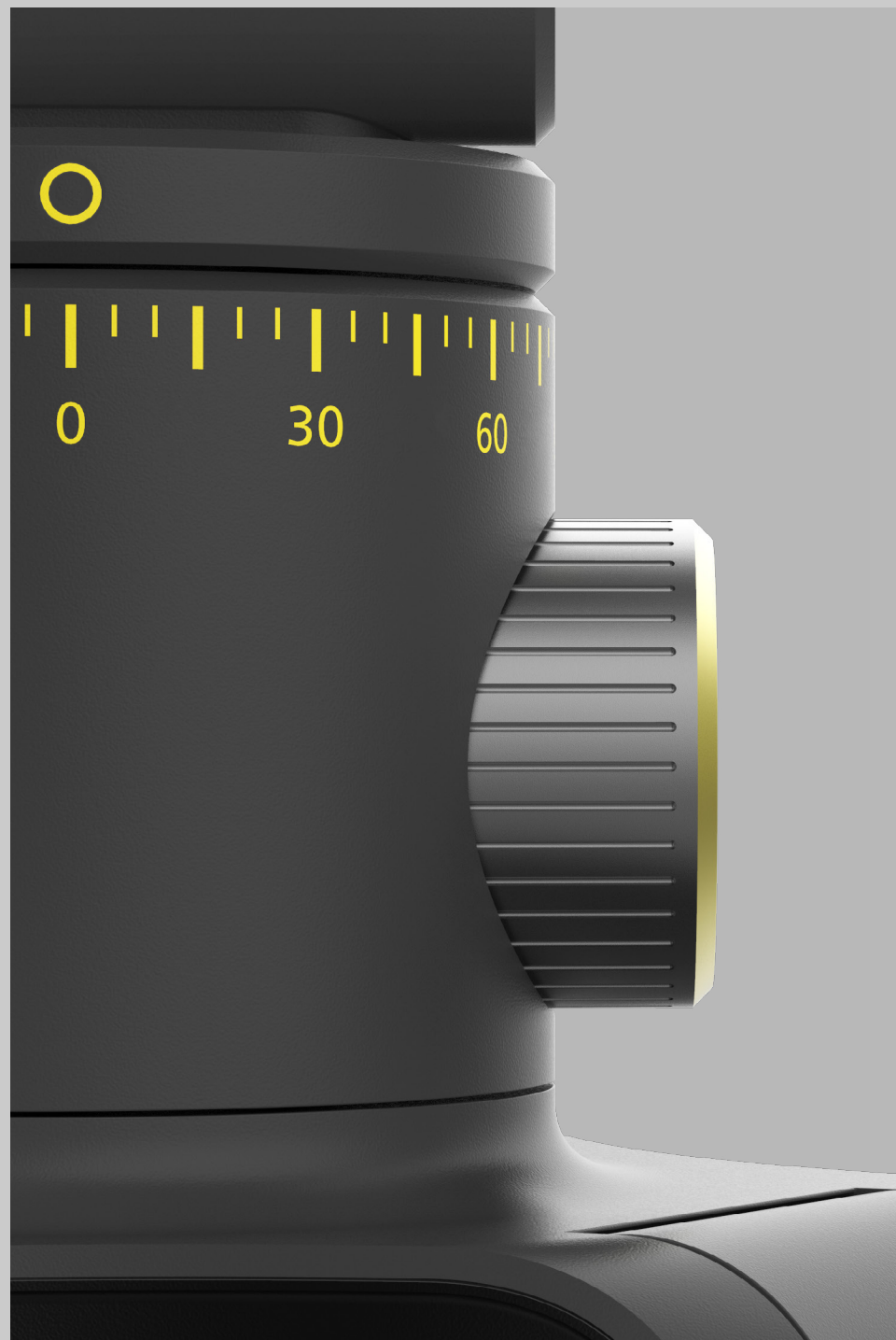

NSK01 | DRONE



NSK01 | DRONE

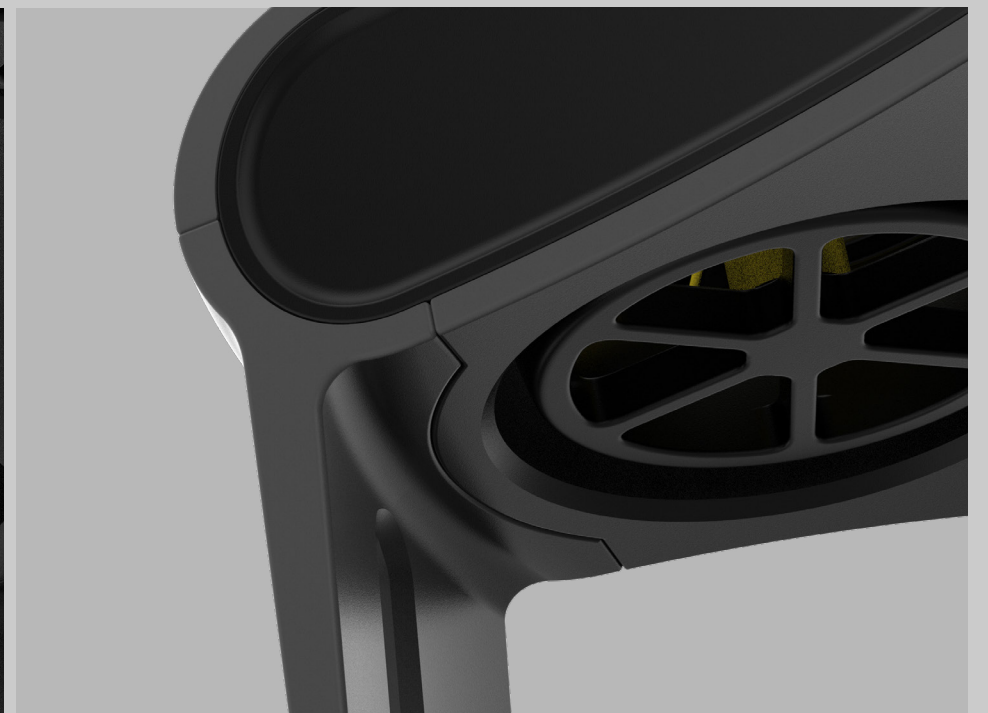

NSK01 | MICROPHONE MOUNT



NSK01 | MICROPHONE DESKTOP STAND





Nikon
NSK01

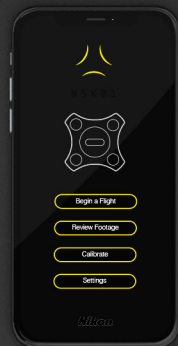

NSK01

Nikon NSK01 acts as the building blocks upon which Nikon's new film maker lineup is built

